



**Metrologic's MS7320 InVista™** offers an outstanding combination of features, versatility, performance, and durability. This fixed mount laser bar code scanner provides ease of use and high throughput speeds by featuring a large, dynamic, and aggressive scan volume.

## MS7320 InVista™

### Features

- **Automatic Scanning Operation**
- **Firmware updates via Flash ROM**
- **EAS deactivation antenna is standard**
- **Supports commonly used interfaces including USB and Keyboard Wedge**
- **Custom edit the bar code data**
- **Powerlink, user replaceable cables**
- **Field replaceable window**
- **RS232 auxiliary port for adding peripherals**
- **OPOS and JPOS system compatible**

Mount or use with or without stand



### Metrologic's MS7320 InVista™

offers an outstanding combination of features, versatility, performance, and durability. This fixed mount laser bar code scanner provides ease of use and high throughput speeds by featuring a large, dynamic, and aggressive scan volume. InVista scanners are sure to provide a positive influence on the productivity of your check out operations by minimizing operator effort and increasing check out speed.

Each InVista is shipped with an integrated EAS deactivation antenna that provides simultaneous scanning and deactivation of security tags, which are used to reduce shrink in retail applications. With a field-replaceable outer window, damaged windows can now be changed easily, eliminating

the need to send the entire unit back for repair. The small footprint takes up minimal counter space while maximizing flexibility with the use of the multi-positioning stand. The setup and integration are simplified by using bar code menus or Windows based software. Supporting multiple interfaces, InVista is compatible with almost every POS system currently on the market. The RS232 auxiliary port allows for hand held scanners or other peripherals to be connected quickly and easily.

With all of the outstanding features, end-users are ensured this scanner will meet the present and future needs of the scanning environments for which it is designed — grocery stores, convenience stores, supermarkets, pharmacies, and specialty stores.



# MS7320 InVista™

## Operational

Light source	Visible Laser Diode 650 nm ± 10nm
Laser Power	0.678 mW (peak)
Depth of Scan Field	0 mm - 215 mm (0" - 8.5") for 0.33 mm (13 mil) bar codes
Width of Scan Field	38 mm (1.5") @ 15 mm (0.6"); 135 mm (5.3") @ 191 mm (7.5")
Scan Speed	2000 scans/sec
Scan Pattern	5 fields of 4 parallel lines (omnidirectional)
Number of Scan Lines	20
Minimum Bar Width	0.127 mm (5.0 mil)
Decode Capability	Autodiscriminates all standard bar codes; for other symbologies call Metrologic
System Interfaces	PC Keyboard Wedge, RS232, OCIA, Light Pen Emulation, IBM 468x/469x, Stand Alone PC Keyboard, USB
Print Contrast	35% minimum reflectance difference
Number Characters Read	Up to 80 data characters
Roll, Pitch, Yaw	360°, 60°, 60°
Beeper Operation	7 tones or no beep
Indicators (LED)	Green = Laser on, ready to scan; Red = Good read, decoding

## Scan Area

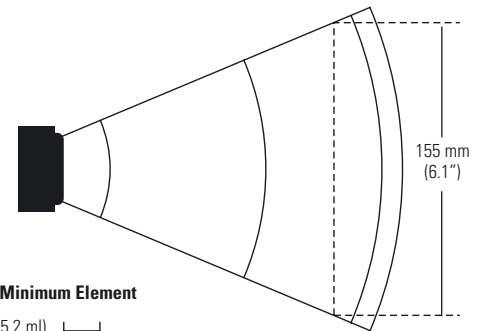

## Bar Code Minimum Element

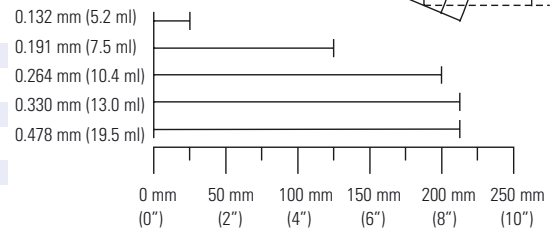

## Mechanical

Dimensions ( without stand )	185 mm H x 99 mm D x 168 mm W (7.3" H x 3.9" D x 6.6" W)
Footprint of Stand	64 mm x 64 mm (2.5" x 2.5")
Weight	1.2 kg (2.65 lbs.)
Termination	Three 10-pin modular RJ45
Cable	Standard 2.1 m (7') straight; for other cables call Metrologic
Mount (optional)	Fully adjustable

## Dimensions

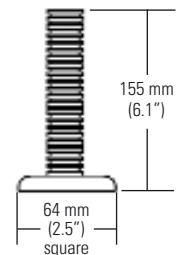
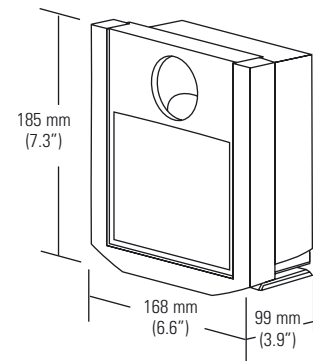

## Electrical

Input Voltage	5.2 VDC ± 0.25 V
Power	1.9 W
Operating Current	360 mA
DC Transformers	Class II; 5.2 VDC @ 650 mA
Laser Class	CDRH; Class IIe; EN60825-1:1994 / A11:1996 Class 1
EMC	FCC; ICES-003 EN55022 Class B

## Environmental

Operating Temperature	0°C to 40°C (32°F to 104°F) Storage Temperature -40°C to 60°C (-40°F to 140°F)
Humidity	5% to 95% relative humidity, non-condensing
Light Levels	Up to 4842 Lux (450 footcandles)
Contaminants	Sealed to resist airborne particulate contaminants
Ventilation	None required

Specifications subject to change without notice.  
Printed in Germany, Copyright February 2002.  
Metrologic, All rights reserved.



RUOSS-KISTLER AG, Kantonsstrasse 55, 8863 Buttikon

Tel.: (+41) 055 464 35 15 Mail: handel@ruoss-kistler.ch  
Fax: (+41) 055 464 35 01 Internet: www.ruoss-kistler.ch